

Darttron

Issuing Entity:
Darttron Industries, Inc
P. O. Box 13114
Salem, Oregon 97309
Phone: 503-362-2341
Fax: 503-362-2536
www.darttronrides.com

Bulletin # PIB-5K-0204-001
Release Date: February 27, 2004
Effective Date: February 27, 2004
Supersedes: N/A
Completion Date: N/A
Page 1 of 6

PRODUCT INFORMATION BULLETIN

Ride Manufacturer:	Darttron Industries, Inc.	Affected Production Dates:	All Cliff Hangers
Ride Name:	Cliff Hanger	Affected Serial #’s:	All
Model #	All Cliff Hangers		

Abstract of Issue: On January 17, 2004, an incident occurred on a Cliff Hanger ride operating in Florida. As a result of the incident, Darttron required Cliff Hanger ride owners to cease operation of Cliff Hangers until they complied with the requirements of Darttron Safety Bulletin SR-5K-002. Additionally, the US Consumer Product Safety Commission recommended that Cliff Hanger rides not be operated until their investigation was complete. On February 27, 2004, CPSC accepted Darttron’s Action Plan and approved Cliff Hanger rides to operate but only upon approval by Darttron of measures taken by the owners/operators in accordance with Darttron Bulletins SR-5K-002, 003, and 004 (see www.darttronrides.com).

Reason for release: To inform Cliff Hanger owners/operators, inspectors and State authorizing authorities of Darttron requirements that must be met before a Cliff Hanger ride can operate. Page 2, 3, 4 and 5 of this bulletin provide a guide for inspecting the Cliff Hanger car suspension components.

Action to be taken: Before a Cliff Hanger ride is allowed to operate, it must comply with the following:

1. The owner/operator must present a Darttron-approved Safe To Operate form (see page 6). The Darttron Safe To Operate Form verifies that the Cliff Hanger complies with Darttron requirements including NDT inspection and that the structural integrity of the gusset joint has not been compromised. It also verifies that a Darttron-approved back-up device is in place. These requirements are found in Safety Bulletins SR-5K-002 and SR-5K-003.
2. Car hangers must be capable of insertion into lower hanger blocks without force, and by April 1, 2004, all Cliff Hangers must have car rack pins cabled to rack turnbuckles (see Bulletin # SR-5K-004).
3. When the Cliff Hanger meets the requirements of numbers 1 and 2 above, it is approved to operate. The Cliff Hanger can be inspected to the drawings attached as Pages 2, 3, 4 and 5 of this bulletin. Any configuration shown is approved if installed correctly and not showing any indications of distress.

Detail of issue: Page 2, 3, 4 and 5 provide inspection guides for approved back-up devices and approved gusset joint configurations. Page 6 is a sample Darttron Safe To Operate form.

PASSENGER CARRIER INSPECTION GUIDE

- ① INSPECT FASTENERS RETAINING MAIN HANGER BLOCK PIVOT PIN TO INSURE 1/2" BOLT JAM NUT, NYLLOCK NUT & COTTER PIN IS INSTALLED.
- ② SHOCK MOUNT BRK-T'S ON SWEEPS #5 & #10 HAVE REMOVABLE PINS, EXAMINE TO SEE THAT PINS ARE SECURE & R KEYS ARE ALL INSTALLED IN BOTH SHOCK MOUNT BRK-T & LOWER HANGER BLOCK.
- ③ CHECK BOLTS & NYLLOCK NUTS ON UPPER & LOWER SAFETY LOOP TO DETERMINE THAT FASTENERS ARE INTACT & SECURE.
- ④ CHECK LOWER HANGER BLOCK PIN FOR EXTERNAL RETAINING RING & ROLL PINS.
- ⑤ CHECK CAR STEM TO HANGER BLOCK PINS, DAILY VERIFY THAT LYNCH PIN & R KEY ARE IN PLACE & PINS ARE SECURE.
- ⑥ CHECK MODIFIED BOLT IN CAR STEM & STEM TO CAR BOLT & NYLLOCK NUT TO DETERMINE THEY ARE SAFE & NUTS HAVE NOT BACKED OFF.
- ⑦ CHECK CAR STRUT PINS ON CAR FRAME & R KEYS TO INSURE THEY ARE IN PLACE & SECURED.
- ⑧ EXAMINE PIVOT POINT ON RESTRAINT TO DETERMINE THAT ALL SHAFTS ARE EXTENDED & HINGES ARE LOCKED IN PLACE.
- ⑨ CHECK CAR HANDLE PIN TO INSURE R KEY IS SNAPPED IN PLACE.
- ⑩ SAFETY CABLE IS THREADED THROUGH BOTH SIDES OF CAR STEM & SECURED TO CAR FRAME

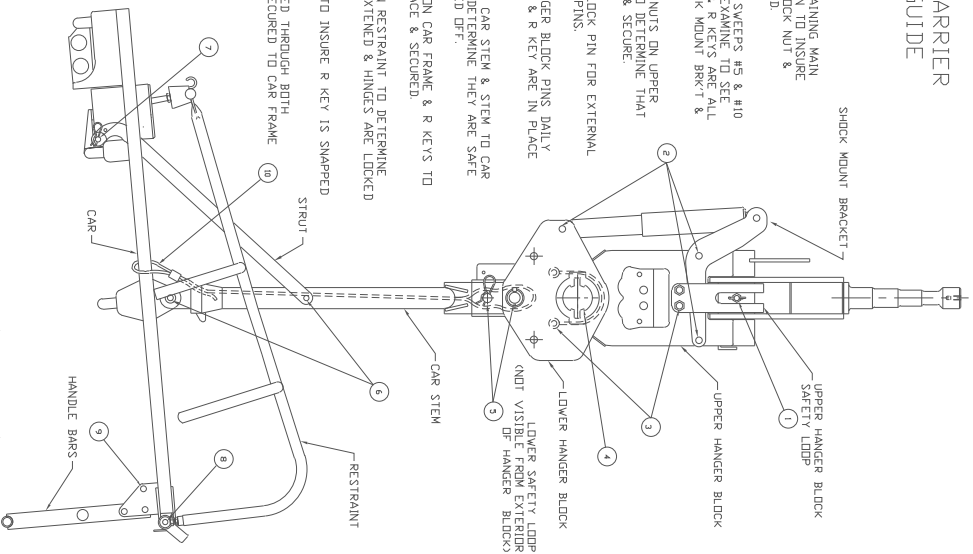

PAGE 2 OF 6 BULLETIN #PIB-SK-0204-001

DARTCO, INC.		DARTCO, INC.		DARTCO, INC.		DARTCO, INC.	
DATE	REV	DATE	REV	DATE	REV	DATE	REV
01/10	1	01/10	1	01/10	1	01/10	1
CARRIER INSPECTION GUIDE				CARRIER INSPECTION GUIDE			
DARTCO				DARTCO			
PIB-SK-0204-001				PIB-SK-0204-001			

PASSENGER CARRIER INSPECTION GUIDE

SHOCK MOUNT BRACKET

- 1 INSPECT FASTENERS RETAINING MAIN HANGER BLOCK PIVOT PIN TO INSURE COTTER PIN IS INSTALLED.
- 2 SHOCK MOUNT BRK-TS ON SWEEPS #5 & #10 HAVE REMOVABLE PINS. EXAMINE TO SEE THAT PINS ARE SECURE & R KEYS ARE ALL INSTALLED IN BOTH SHOCK MOUNT BRK-T & LOWER HANGER BLOCK.
- 3 CHECK BOLT'S & NUTLOCK NUTS ON UPPER & LOWER SAFETY LOOP DETERMINE THAT FASTENERS ARE INTACT & SECURE.

- 4 CHECK LOWER HANGER BLOCK PIN FOR EXTERNAL RETAINING RING & ROLL PINS.
- 5 CHECK CAR STEM TO HANGER BLOCK PINS DAILY VERIFY THAT LYNCH PIN & R KEY ARE IN PLACE & PINS ARE SECURE.
- 6 CHECK MODIFIED BOLT¹ IN CAR STEM & STEM TO CAR BOLT & NUTLOCK AND TO DETERMINE THEY ARE SAFE & NUTS HAVE NOT BACKED OFF.
- 7 CHECK CAR STRUT PINS ON CAR FRAME & R KEYS TO INSURE THEY ARE IN PLACE & SECURED.

- 8 EXAMINE PIVOT POINT ON RESTRAINT TO DETERMINE THAT ALL SHAFTS ARE EXTENDED & HINGES ARE LOCKED IN PLACE.
- 9 CHECK CAR HANDLE PIN TO INSURE R KEY IS SWAPPED IN PLACE.
- 10 SAFETY CABLE IS THREADED THROUGH THE ARCH ASSEMBLY ONLY & SECURED TO CAR FRAME.

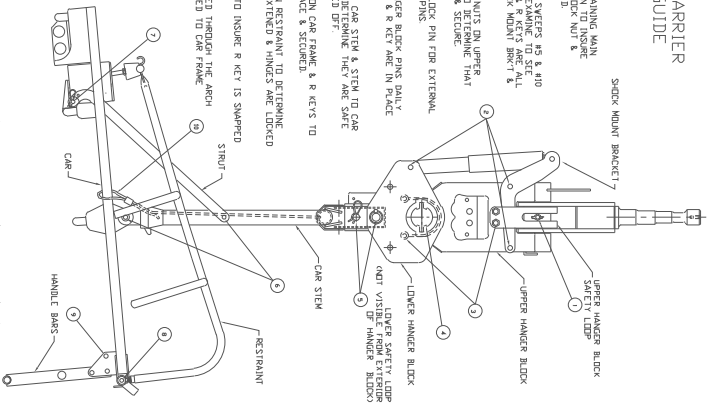

Darttron Industries, Inc.

In accordance with Safety Bulletin # SR-5K-002 Darttron has received a NDT Magnetic Particle and a Back Up Device Report for Cliff Hanger Serial Number _____.

The Mag Particle Report provided the below information about the gusset to Stem joint:

Gusset Joint Uncompromised on car: 1 2 3 4 5 6 7 8 9 10 none

Allowable defects were found on cars: 1 2 3 4 5 6 7 8 9 10 none

Action Required _____

Action Required _____

Action Required _____

Rejected car hanger stems were found on cars:

1 2 3 4 5 6 7 8 9 10 None

Rejected car hangers must be replaced with a new car hanger purchased from Darttron Industries.

Summary of NDT action taken:

Successfully Completed Inspection: _____

Rejected: _____ Status of Rejected Stems: _____

Summary of Back Up device installation:

Original Cable _____

Retrofit Strap _____

Information provided by: _____

Cliff Hanger S/O # _____ owned by _____ complied with the NDT and backup device requirements of Safety Bulletin # SR-5K-002 on the date of _____ and is determined by Darttron Industries, Inc. to be safe to operate.

J. Robert Coil – President
Darttron Industries, Inc.