

Dartron

Issuing Entity:
Dartron Industries, Inc

P. O. Box 13114
Salem, Oregon 97309
Phone: 503-362-2341
Fax: 503-362-2536

www.dartronrides.com

Bulletin # BU-935

Release Date: May 27, 1994

Effective Date: May 27, 1994

Supersedes: None

Completion Date: N/A

Page 1 of 5

SERVICE BULLETIN

Ride Manufacturer: Dartron Industries, Inc.

Affected Production Dates: 1991-1993

Ride Name: StarTrooper

Affected Serial #'s 111141-5S, 210211-5S, 210301-5S,
210091-5S, 212081-5S, 212071-5S, 301181-5S

Model #

Abstract of Issue: All StarTrooper's with car storage racks with chain restraint systems.

Reason for release:

The StarTrooper has three car storage racks on the gooseneck platform. In the transport position hydraulically raised to a position above the gooseneck platform. The car storage racks are held in the transport position by (1) pressure from the hydraulic system (2) the over center position of the car storage racks and (3) a safety chain that attaches between the racks and the gooseneck platform.

Action to be taken: It has come to our attention in the event of a failure of the hydraulic system holding the car racks in position, if the safety chain is attached loosely, the safety rack could fall to the lowered position and cause the chain to break. Because of this possibility Dartron has developed a turnbuckle holding device that will ensure that the storage racks cannot drop to the unload position in the event of a hydraulic failure. Until the turnbuckle kit is installed, you must wrap a cargo strap or chain or similar device around all three car storage racks as a precaution against a hydraulic failure causing the racks to lower to the unload position.

Caution: Failure to place a strap around all three storage racks during the transport mode or to install the turnbuckle kit could result in damage to the cars, the transport vehicle or other traffic.

Parts Availability: A turnbuckle kit including the parts listed on page three will be supplied to you without charge. To receive your kit call Steve Jones at 503-362-2341 and inform him of the location and ate you want to receive the kit.

Tools Required: The tools you will need to supply to install the turnbuckle kit are listed on page three.

Installation Instructions: Following are instruction to install turnbuckles, which have proven to be a more positive fastening device. Drawings are included in this bulletin to provide orientation to parts being modified or added.

Connect electrical power, lower car storage frame; remove cars and clear trailer gooseneck of obstruction.

Rear car storage frame turnbuckle installation:

1. Drill an 11/16-diameter hole in storage frame stops on trailer gooseneck (fig 1).
2. Trim supplied turnbuckle lugs (item 11) to fit storage frame (fig 2).
3. Establish centerline of frame. Weld turnbuckle lug (item 11) on center (fig 3).
4. Install short turnbuckle (item 12) with jam nut end (item 9) toward storage frame; install pin with R key. Install trailer side turnbuckle endpin; secure with cotter pin.

Front car storage frame turnbuckle installation:

1. Unbolt and remove deck plate located at front of trailer.
2. Measure and locate centerline of trailer gooseneck. Mark center on cross member approximately thirty inches from front of trailer. Measure five inches toward left (street) side of trailer and mark. Weld turnbuckle (item 9) lug to cross member on mark (fig 4).
3. Weld supplied brace in cross member (structural channel) directly under turnbuckle lug.
4. Trim deck plate (item 9) to fit and reinstall.
5. Raise front storage frame to full upright position.
6. Measure storage frame and mark centerline. Measure five inches toward left (street) side and mark (fig 5).
7. Measure and mark centerline of turnbuckle lug. Center log on mark and tack in place. Install long turnbuckle and check fit. Weld permanently (fig6).
8. With jam nut towards storage frame and pins installed, secure with cotter pin and R key.

Parts included in turnbuckle kit:

4 turnbuckle lugs	1 cross member
2 short turnbuckles w/pins	3 R keys
3 cotter pins	

Tools needed to install:

Scribe	Drill motor
Hammer	Hand grinder
Center Punch	7/16 wrench
Adjustable square	Welder
Tape measure	Acetylene torch
11/16-drill bit	12" adjustable wrench

Attachment: Figure 1-6, rear car stowage frame drawing, front car stowage frame assembly drawing.

BULLETIN #935

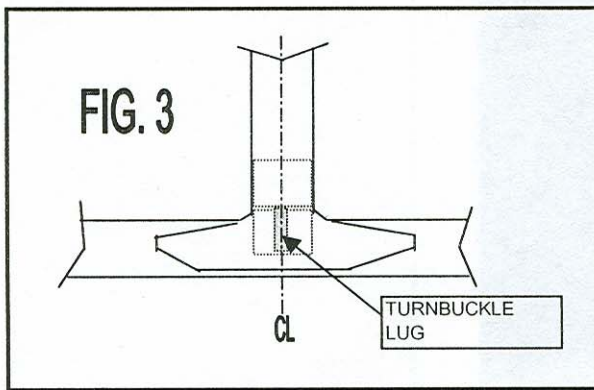
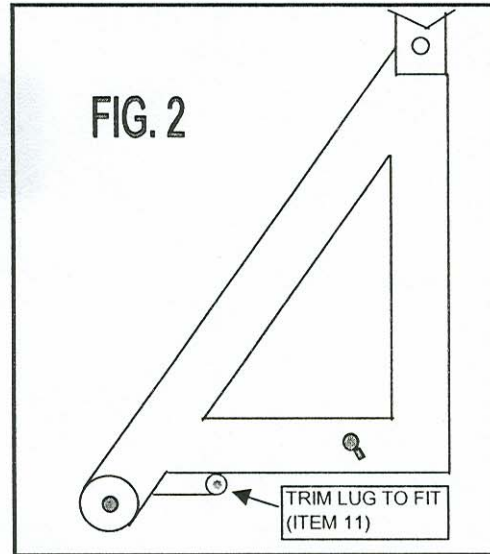
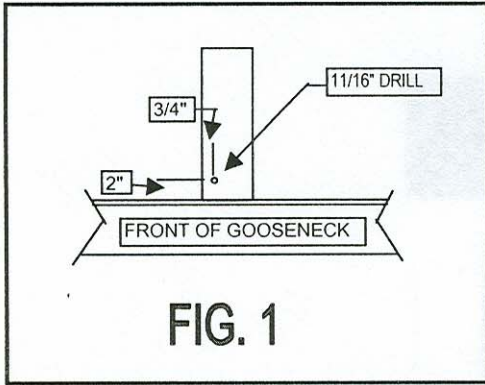

BULLETIN #935

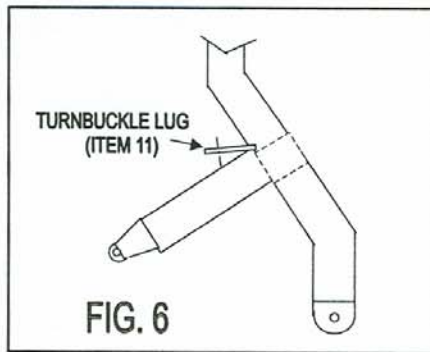
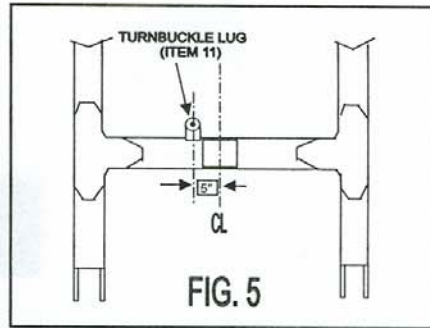
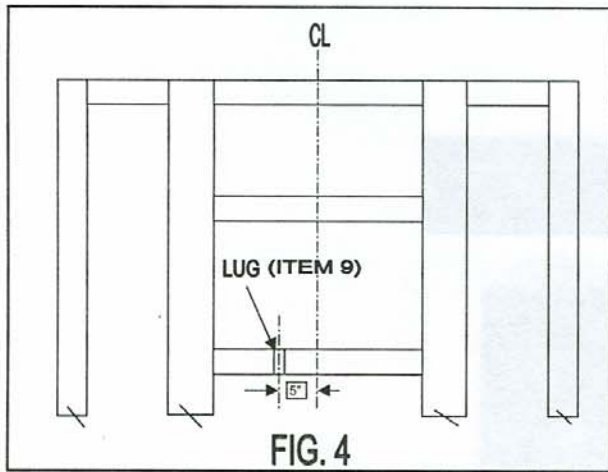

BULLETIN #935

